

# Fillet Splitter

Type K

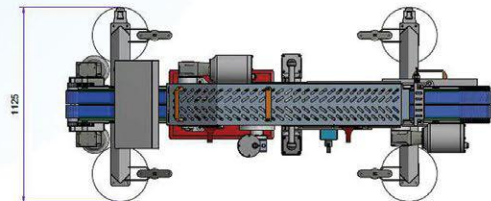
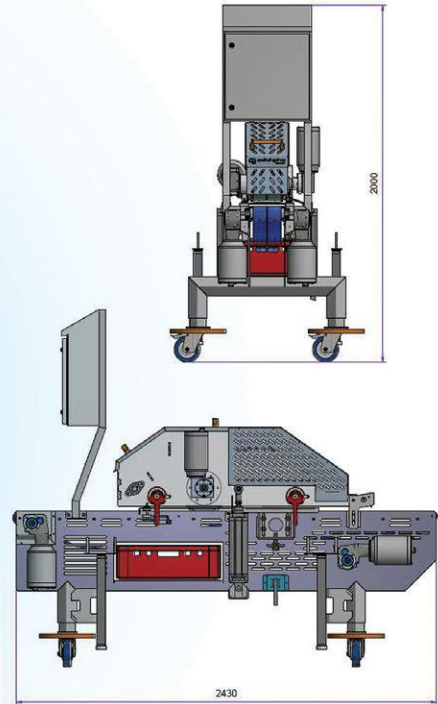
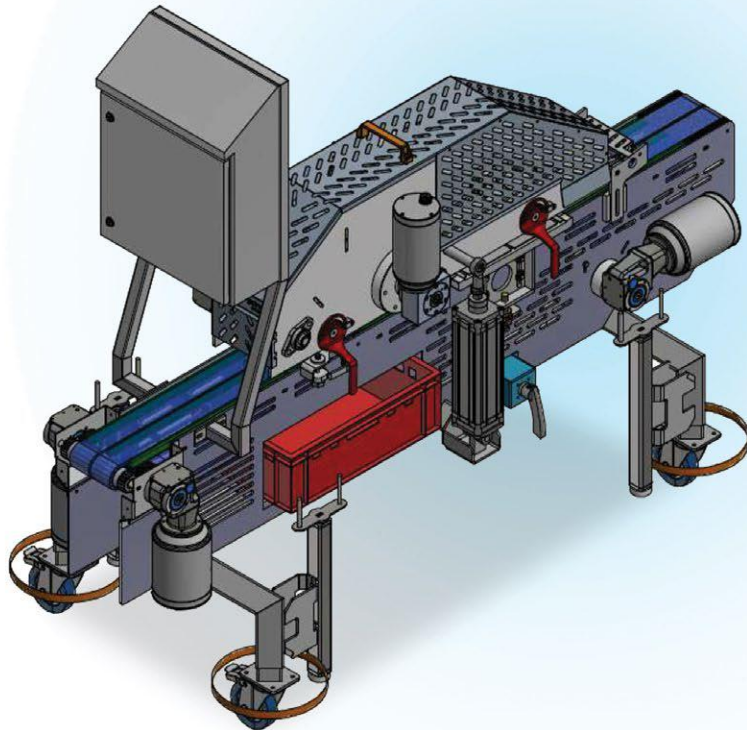

The **Cantrell•Gainco Fillet Splitter**, powered by Wichelmann, is designed to cut fillets of chicken and other meats horizontally and vertically.

Thanks to the unsurpassed quality of German precision engineering, you can rely on quick, efficient processing for a better-quality finished product.

- Process up to **240 pieces per minute**, based on your production requirements.
- The machine processes raw material items sized as large as **8" x 6" x 2"** (200 x 150 x 50 mm).

Along with our fixed-weight portion cutting equipment, we have you covered when it comes to processing boneless premium cuts of meat!

## Technical Information

<b>Dimensions:</b>	8' x 3.7' x 6.6' (2,430 x 1,125 x 2,000 mm)
<b>Weight:</b>	1,074 lbs. (487 kg)
<b>Power:</b>	2.5 kW
<b>Fuse:</b>	2.8A / 60 Hz
<b>Air pressure:</b>	6-8 bar