

**FORMOST FUJI**

# **CX II**

# **FLOW WRAPPER**

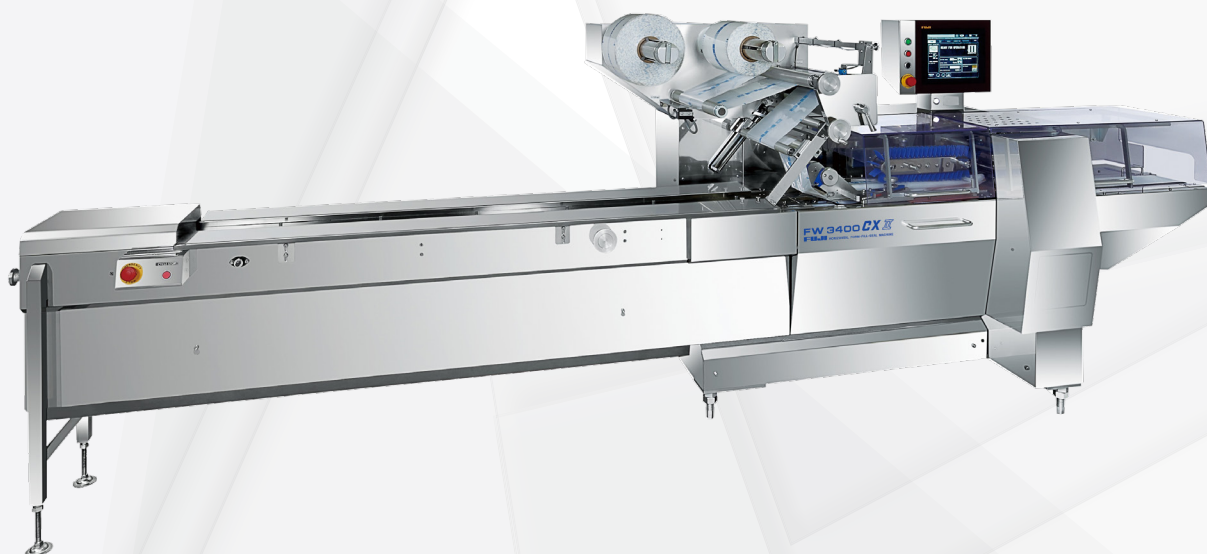

**Proven Advanced Technology,  
Energy Saving Operation,  
Maintenance Friendly**

**FW3400/3410 CX II • FW3400B/3410B CX II**

**[www.formostfuji.com](http://www.formostfuji.com)  
425-483-9090**

# FEATURES & SPECIFICATIONS:

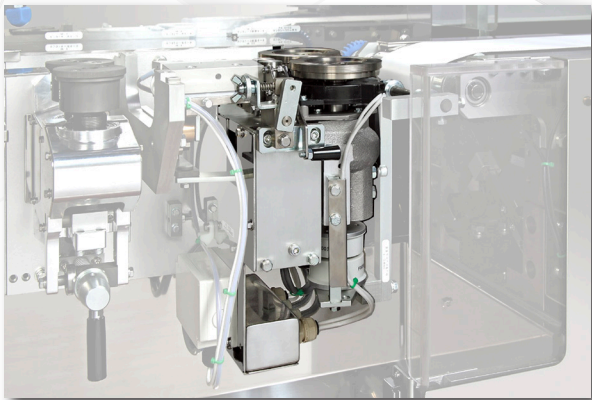

## ENERGY SAVING - INDUCTION HEATING

Energy saving technology, maintenance free design, faster temperature and accuracy



## NON-CONTACT SENSOR

New type of sensor to detect end of film roll

## EASY MAINTENANCE

Simple removal of the discharge conveyor provides easy access for cleaning and saves time for maintenance.

## UNIVERSAL DESIGN INTERFACE

Operator interaction with the machine is simple and straightforward. This HMI is design so that "anyone will find it easy to use"

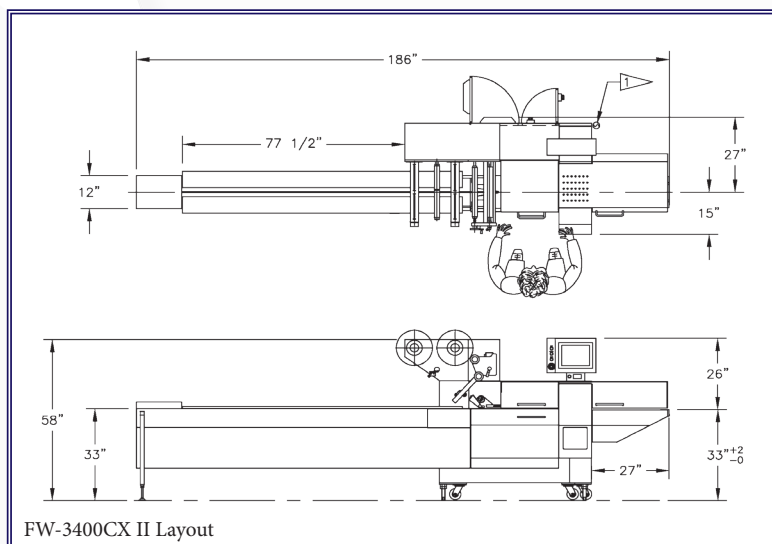

Machine Model	FW-3400CX II	FW-3400B CX II	FW-3410CX II	FW-3410B CX II
<b>Operating Speed *</b>	10-300 ppm	10-150 ppm	10-180 ppm	10-140 ppm
<b>Motor</b>	Infeed Conveyor, Film Feed, Center Sealers, and End Sealers Drive: Yaskawa Sigma VII Servos			
<b>Film Roll</b>	Max Width	16-15/16 inches	16-15/16 inches	23-5/8 inches
	Max Diameter	11-13/16 inches	11-13/16 inches	11-13/16 inches
	Max Weight	Max. 55 lbs.	Max. 55 lbs.	Max. 55 lbs.
<b>Product Dimension</b>	Max. Width	5-1/2 inches	5-1/2 inches	7-7/8 inches
	Max. Height	4 inches	4 inches	5 inches
<b>Machine Weight</b>	Approx. 1875 lbs.	Approx. 2200 lbs.	Approx. 1875 lbs.	Approx. 2425 lbs.

\*Higher speeds and longer cutoff lengths are available for specific applications.

Specifications may vary according to application. Changes may be made without notice.



19211 144<sup>th</sup> Avenue NE • Woodinville, WA 98072

Phone: 425-483-9090 • Fax: 425-486-5656 • email: sales@formostfuji.com

[www.formostfuji.com](http://www.formostfuji.com)